

AR3 Regulator with Electric Wide Opening

## INTRODUCTION

These advanced-design, strong-bodied, precision-manufactured MODULAR regulators are superior in their ability to overcome dirt and sticky oil during opening and tight closing. Models are now available for nearly every control function requirement of subcritical CO<sub>2</sub> refrigeration systems, industrial ammonia and commercial halocarbon refrigeration. These regulators are ideal for cold storage plants, poultry plants, meat packing, fish processing, freezers, ice plants, breweries, bottling plants, heat recovery units, petrochemical plants, pharmaceutical plants, supermarkets, and many others. Applicable for CO<sub>2</sub>, FREON as well.

## APPLICATIONS

- Evaporator Pressure Control
- Defrost Pressure Control
- Condensing Pressure Regulation
- Receiver Pressure Control
- Hot Gas Bypass Capacity Regulation
- Suction Pressure Control
- Air or Liquid Temperature Regulation
- Internal System Pressure Relief

## Specifications, Applications, Service Instructions & Parts

### CARW MODULAR PRESSURE REGULATORS 3/4" THROUGH 3" PORT (20MM THROUGH 76MM)

### Various Connection Sizes for Refrigerants

## KEY FEATURES

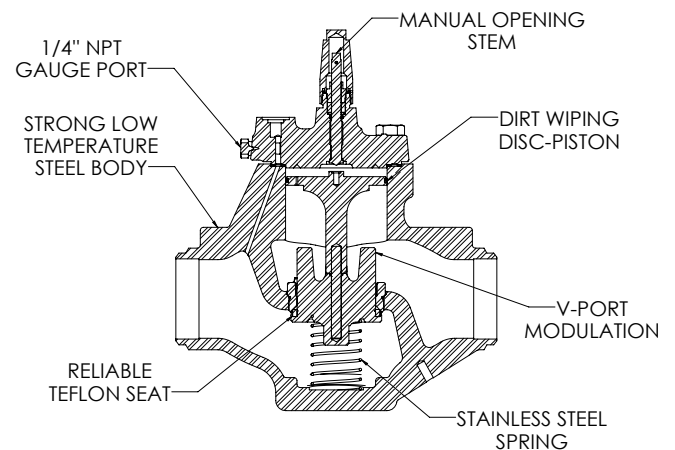

## ADDITIONAL FEATURES

- Zinc plated as standard
- Tolerant of Dry Systems
- For CO<sub>2</sub> Ammonia, R22, R507, R134a and other Hansen-Approved Refrigerants
- Wide Range of Options
- Wide Pressure Ranges
- Able to configure into Solenoid valve, Inlet regulator, Electric Shut-Off, Dual, or Wide-Opening
- Safe Working Pressure: 754 psig (52 bar)

Contents	Page
Regulator Variations	3
Capacities	4-5
Control Modules (Pilots)	6
Main Regulators Only (AR1, AR3)	7
Operation and Adjustment	8-11
Installation Dimensions	12-13
Parts List	14-18
Service and Maintenance, Abbreviations	19
Ordering Information, Conversions	20

## MATERIAL SPECIFICATIONS

Body: 3/4" through 3": Cast steel, ASTM A352 LCB

Adapter: Cast steel, ASTM A352 LCB

Piston: Steel, disc type, Teflon piston seal

V-Port/Seat: ductile iron, with Teflon seat

Main Seat: stainless steel, removable

Gaskets: Nonasbestos, graphite composite

Manual Opening Stem: Stainless Steel

Pilots: Carbon Steel

Pilot Orifice: Stainless steel

Safe Working Pressure: 754 psig (52 bar)

Operating Temperature: -60°F to +240°F (-50°C to +115°C)

MOPD: 300 PSID with MS Operator

580 PSID with MSHP operator

## ADVANTAGES

These valves and control modules are now designed to operate at higher operating pressures required for subcritical CO2 refrigeration systems while still maintaining the ability to use in ammonia, halocarbons, or other approved refrigerants. These valves combine modern design and new age materials with advanced manufacturing techniques and intense quality control to offer a significantly superior and reliable product. They use low temperature cast steel bodies and adapters, and low temperature bolts which make it highly suitable for the demanding conditions of CO2 refrigeration systems. All regulators and pilot modules are zinc plated as standard to provide corrosion resistance. The v-port assemblies have been redesigned to secure the Teflon seat within a groove, ensuring it stays in place more effectively in all approved refrigerants. These valves are more dirt resistant than full skirted-piston-design valves. All regulators use energized Teflon dirt-wiping piston seals which operate reliably, even under dry, oil-free conditions. The screw-on control modules (pilots) are easy to change and can be used on all valve sizes. All valves incorporate Teflon seating and stainless steel spring closing. Stainless steel Manual-opening stems are located on top of valves, up and away from dirt and rust particles to avoid thread jamming. Nonasbestos gaskets are standard.

## SIZING

Proper regulator valve sizing is important for smooth operation and long, trouble-free life of the valve. Therefore, capacity of the regulator at both the maximum and minimum flow and pressure drop should be analyzed. Pressure regulators will operate satisfactorily to approximately 15% of the maximum capacity of valve based on the corresponding pressure drop. In extreme cases, downsizing or two smaller regulators in parallel are necessary. For pressure drops exceeding 45 psi (3.1 bar g), special construction may be required. Contact the factory.

It is recommended to use Hansen's Sizing, Selection, and Quoting Tool available on its website. The Hansen sizing software can be found at [valveselect.hantech.com/Projects/Configuration](http://valveselect.hantech.com/Projects/Configuration). Please create a new account to use its features such as:

- Quoting

Quickly see how much your project will cost and weigh for better planning and optimization.

- Sizing

This tool allows you to size the pressure regulator needed for your application based on refrigeration load, evaporator temperature, outlet pressure, and the liquid (Make-up) temperature

- The sizing software also has a P/T Table available for your reference

## INSTALLATION

Regulators should be protected from dirt and moisture during storage. If valves are stored or remain non-functional for extended periods, the valve piston seal may require reconditioning. To do this, apply a small amount of refrigerant oil to the valve bore and manually move the valve piston up and down several times until it operates smoothly. The arrow on the body should be in the normal direction of refrigerant flow. *These valves will not prevent reverse flow*; use check valves where necessary. Regulators are normally in horizontal pipe lines with pilots and manual-opening stems on top. Do not rotate the position of the valve adapter or the valve will not operate.

Hansen CARW regulator valve bodies and adapter covers kits are sold separately from the required screw in modules. To make a fully functioning valve configuration, the customer must field assemble the appropriate control modules and port gaskets into the adapter cover. Recommended torque to install these modules is 75 ft-lbs. Consult the below sections on regulator variations for descriptions of each control module and model variations for instructions on the appropriate parts to purchase and how to assemble for each possible variation.

Take care to not exceed the pressure or temperature ratings of components when combining components or control modules from the standard Hansen product line with a CARW valve kit, as these components are typically not rated for the same duty cycle.

The system should be free of dirt, weld slag, and rust particles. It is typical to install a strainer immediately preceding the regulator. No small, hidden, internal screens are used. Gauges and gauge valves should be installed on the inlet and outlet to help in system diagnosis. Where pilot solenoid control modules are used, the nameplate coil voltage should be checked before wiring. Pipe sizing, anchoring, valve rating, system design, and other precautionary factors should be taken into consideration to ensure "liquid hammer" will not occur when the valve opens or closes.

These valves are integral butt weld end only. These steel-bodied regulators are directly welded into the pipe line. During welding, the manual-opening stem should be opened downward several turns to protect the Teflon seat from weld heat.

Welds should be annealed and examined as necessary in accordance with good practice or local regulations. Painting of valves and welds is recommended for corrosion protection. Pipe covering, where applied, should have proper moisture barrier. Before putting valves into service, all pipe connections, valve seats, cover seals, and stem seals should be tested for leaks at pressure levels called for in appropriate codes.

## ELECTRICAL

When the solenoid, electric shut-off, wide-opening, or dual regulating configuration is created, a Hansen low-wattage, molded electrical coil needs to be purchased. The standard coil voltage rating is 208/230V, and features a DIN connector or other voltages available - contact factory. The coil properly operates between 85% and 110% of the rated voltage. Coils should only be energized while on the pilot solenoid tube.

**DIN Plug Coil kits** are for grounded cord connections and include the necessary DIN plug socket with gasket coil knob and O-ring.

- Coil Kit: 220VAC DIN WITH KNOB, DIN PLUG, O-RING, DIN PLUG GASKET

## REGULATOR/SOLENOID VARIATIONS

### STANDARD REGULATOR

This most common pressure regulator modulates to control evaporator pressure, condensing pressure, pressure in a vessel, or pressure in a portion of a system. It is frequently called an evaporator pressure regulator (EPR) or back pressure regulator. Opens on rising inlet pressure. See page 10. Shown with M3W pilot.

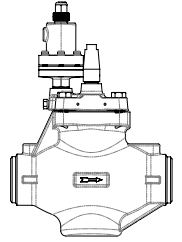

### REGULATOR WITH ELECTRIC SHUT-OFF

This control is commonly used for temperature control or defrost. Regulates at the set-for pressure when energized. When de-energized, the valve closes tight regardless of the pressure setting. See page 11.

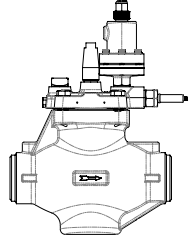

### REGULATOR WITH ELECTRIC WIDE OPENING

This control is commonly used for temperature control or defrost. Regulates at the set-for pressure when energized. When de-energized, the valve closes tight regardless of the pressure setting. See page 11.

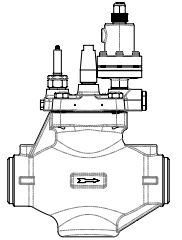

### DUAL PRESSURE REGULATOR

Regulates (evaporator) pressure at a setting when energized, and at a higher setting for defrost, temperature control, or pressure relief when de-energized. See page 11.

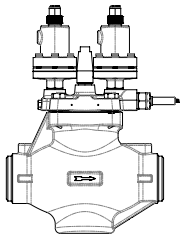

### STANDARD SOLENOID

Controls the on-off flow of refrigerant. When energized, the valve will fully open. When de-energized the valve will close tight. Requires a 2-3 psi pressure drop across the valve to fully open with the MS and a 5 psi drop with the MSHP.

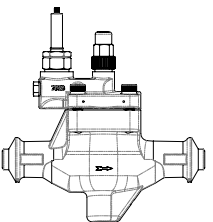

**CAPACITIES (TONS)**  
(1 Ton=12,000 Btu/hr=3.517 kW=3042 kcal/hr)

PORT SIZE (mm)	Cv (Kv)	PRESSURE DROP ACROSS VALVE†	CO2					R507				
			EVAPORATING TEMPERATURE					EVAPORATING TEMPERATURE				
			-40°F† (-40°C)	-20°F† (-28.9°C)	0°F (-17.8°C)	+20°F (-6.7°C)	+40°F (+4.4°C)	-40°F† (-40°C)	-20°F† (-28.9°C)	0°F (-17.8°C)	+20°F (-6.7°C)	+40°F (+4.4°C)
¾" (20)	6.4 (5.5)	2 psi	3.9	4.9	11	7.4	8.8	-	-	-	-	4.2
		5 psi	6.1	7.7	9.5	12	14	-	-	3.8	5.1	6.6
		10 psi	8.5	11	6.7	16	20	-	3.6	5.1	6.9	9
		20 psi	12	15	9.3	23	28	-	3.8	6.2	8.9	12
1" (25)	11.7 (10)	2 psi	-	9	11	13	16	-	-	-	-	-
		5 psi	11	14	17	21	25	-	-	-	9.3	12
		10 psi	15	20	24	30	36	-	-	9.3	13	17
		20 psi	21	27	34	42	-	-	-	11	16	22
1¼" (32)	16.4 (14)	2 psi	10	13	16	19	23	-	-	-	8.4	11
		5 psi	16	20	24	30	36	-	-	9.8	13	17
		10 psi	22	28	34	42	-	-	9.1	13	18	23
		20 psi	30	38	-	-	-	-	9.6	18	23	31
1½" (40)	35 (30)	2 psi	-	27	33	40	48	-	-	-	-	-
		5 psi	33	42	52	64	76	-	-	-	28	36
		10 psi	46	59	73	89	-	-	-	28	38	49
		20 psi	63	81	102	-	-	-	-	34	48	66
2" (50)	47 (40)	2 psi	-	36	44	54	65	-	-	-	-	31
		5 psi	45	57	70	85	102	-	-	-	37	48
		10 psi	62	79	98	120	-	-	-	37	51	66
		20 psi	85	109	-	-	-	-	-	46	65	88
2½" (65)	77 (66)	2 psi	-	59	73	89	106	-	-	-	-	-
		5 psi	73	93	115	140	167	-	-	-	61	79
		10 psi	102	130	161	-	-	-	-	61	83	109
		20 psi	139	-	-	-	-	-	-	75	107	144
3" (80)	104 (89)	2 psi	-	80	98	120	143	-	-	-	-	69
		5 psi	99	125	155	189	226	-	-	-	82	107
		10 psi	137	175	218	-	-	-	-	82	112	147
		20 psi	187	-	-	-	-	-	-	101	144	195

i= 0.14 bar g                      5 psi= 0.35 bar g                      10 psi= 0.69 bar g                      20 psi= 1.38 bar g

\*Optional 25% or 50% reduced capacity ¾" (20 mm) plugs are available for unusually low loads if requested.

† -40°F (-40°C) and -20°F (-28.9°C) capacities are based on a cascade system.

For liquid overfeed evaporator suction between normal 2:1 to 5:1 rate, add 20% to the evaporator load or use the next larger port size to accommodate liquid volume accompanying the suction gas and to reduce impact velocity.

**Conditions:** Capacities are based on the evaporator temperatures shown and +86°F (+30°C) liquid. R717: For each 10°F (5.6°C) lower liquid temperature, increase the above table capacity by 3%. R22: For each 10°F (5.6°C) lower liquid temperature, increase the above table capacity by 5%. To convert for R134a, multiply the R22 table values by 0.73 (accuracy within 8%). For other refrigerant capacities and suitability, contact the factory.

**CAPACITIES (TONS)**  
(1 Ton=12,000 Btu/hr=3.517 kW=3042 kcal/hr)

PORT SIZE (mm)	Cv (Kv)	PRESSURE DROP ACROSS VALVE‡	R717					R22				
			EVAPORATING TEMPERATURE					EVAPORATING TEMPERATURE				
			-40°F† (-40°C)	-20°F† (-28.9°C)	0°F (-17.8°C)	+20°F (-6.7°C)	+40°F (+4.4°C)	-40°F† (-40°C)	-20°F† (-28.9°C)	0°F (-17.8°C)	+20°F (-6.7°C)	+40°F (+4.4°C)
¾" (20)	6.4 (5.5)	2 psi	4.7	6.4	7.4	9.5	12	2.1	2.8	2.8	3.6	4.4
		5 psi	6.7	9.7	8.7	15	19	3.2	4.3	4.4	5.5	6.9
		10 psi	—	13	15	20	26	—	5.8	6.0	7.7	9.6
		20 psi	—	—	19	27	35	—	—	7.8	10	13
1" (25)	11.7 (10)	2 psi	8.5	12	13	17	22	3.9	5.2	5.2	6.5	8.0
		5 psi	12	18	16	27	34	5.8	7.9	8.0	10	13
		10 psi	—	23	28	37	47	—	11	11	14	18
		20 psi	—	—	36	49	64	—	—	14	19	24
1¼" (32)	16.4 (14)	2 psi	12	16	19	24	31	5.4	7.2	7.2	9.1	11.3
		5 psi	17	25	22	38	48	8.1	11	11	14	18
		10 psi	—	32	39	52	66	—	15	15	20	25
		20 psi	—	—	50	69	90	—	—	20	26	34
1½" (40)	35 (30)	2 psi	25	35	40	52	65	12	15	15	19	24
		5 psi	37	53	48	81	102	17	24	24	30	38
		10 psi	—	69	84	111	141	—	31	33	42	53
		20 psi	—	—	106	147	193	—	—	43	56	72
2" (50)	47 (40)	2 psi	34	47	54	70	87	16	21	21	26	32
		5 psi	49	71	64	108	137	23	32	32	41	51
		10 psi	—	92	113	149	190	—	42	44	56	71
		20 psi	—	—	143	198	259	—	—	57	76	96
2½" (65)	77 (66)	2 psi	56	77	89	114	143	25	34	34	43	53
		5 psi	81	116	105	177	224	38	52	53	67	83
		10 psi	—	151	185	243	311	—	69	72	92	116
		20 psi	—	—	234	324	424	—	—	94	124	158
3" (80)	104 (89)	2 psi	76	104	120	154	193	34	46	46	58	71
		5 psi	109	157	141	239	303	51	70	71	90	112
		10 psi	—	204	250	329	420	—	93	97	125	156
		20 psi	—	—	316	438	572	—	—	127	167	213

‡ 2 psi= 0.14 bar g

5 psi= 0.35 bar g

10 psi= 0.69 bar g

20 psi= 1.38 bar g

\*Optional 25% or 50% reduced capacity ¾" (20 mm) plugs are available for unusually low loads if requested.

† -40°F (-40°C) and -20°F (-28.9°C) capacities are based on a two stage system.

For liquid overfeed evaporator suction between normal 2:1 to 5:1 rate, add 20% to the evaporator load or use the next larger port size to accommodate liquid volume accompanying the suction gas and to reduce impact velocity.

**Conditions:** Capacities are based on the evaporator temperatures shown and +86°F (+30°C) liquid. R717: For each 10°F (5.6°C) lower liquid temperature, increase the above table capacity by 3%. R22: For each 10°F (5.6°C) lower liquid temperature, increase the above table capacity by 5%. To convert for R134a, multiply the R22 table values by 0.73 (accuracy within 8%). For other refrigerant capacities and suitability, contact the factory.

## HOT GAS DEFROST NOMINAL VALVE SIZING CAPACITIES (DEFROSTING EVAPORATOR SIZE TONS)

REFRIG.	APPLICATION	PORT SIZE (mm)					
		¾" (20)	1" (25)	1¼" (32)	1½" (40)	2" (50)	2½" (65)
CO2	Hot Gas Solenoid*	8 to 16	16 to 24	24 to 45	45 to 75	75 to 115	115 to 144
	Defrost Relief Regulator	12 to 30	30 to 47	47 to 68	68 to 96	96 to 145	145 to 180
R507	Hot Gas Solenoid*	2 to 4	4 to 8	8 to 12	12 to 20	20 to 38	38 to 60
	Defrost Relief Regulator	8 to 11	11 to 21	21 to 30	30 to 43	43 to 58	58 to 95

REFRIG.	APPLICATION	PORT SIZE (mm)					
		¾" (20)	1" (25)	1¼" (32)	1½" (40)	2" (50)	2½" (65)
R717	Hot Gas Solenoid*	9 to 15	15 to 28	28 to 39	39 to 73	73 to 106	106 to 165
	Defrost Relief Regulator	17 to 24	24 to 45	45 to 60	60 to 96	96 to 140	140 to 225
R22	Hot Gas Solenoid*	6 to 8	8 to 15	15 to 20	20 to 32	32 to 47	47 to 75
	Defrost Relief Regulator	6 to 8	8 to 15	15 to 20	20 to 32	32 to 47	47 to 75

\*Or an outlet pressure regulator with electric shut-off (HA4AOS).

Evaporator tons at 10°F (5.6°C) TD (temperature differential), valve capacities are conservative. These capacities can be modified up or down depending on type of evaporator, temperature, mass, frost thickness, defrosting time, etc. Typical for -20°F (-28.9°C) evaporator.

### GAS CAPACITIES (TONS)\*

(1 Ton=12,000 Btu/hr=3.517 kW=3042 kcal/hr)

SIZE (mm)	DISCHARGE GAS REGULATOR				HOT GAS BY-PASS TO SUCTION			
	R717		R22		R717		R22	
	+86°F (+30°C) CONDENSING +140°F (+60°C) DISCHARGE		+86°F (+30°C) CONDENSING +140°F (+60°C) DISCHARGE		+86°F (+30°C) CONDENSING +140°F (+60°C) DISCHARGE	+15°F (-9.4°C) CONDENSING +15°F (-9.4°C) DISCHARGE †	+86°F (+30°C) CONDENSING +140°F (+60°C) DISCHARGE	+15°F (-9.4°C) CONDENSING +15°F (-9.4°C) DISCHARGE †
	2 psid	5 psid	2 psid	5 psid				
¾" ** (20)	17	27	6.1	9.5	88	27	32	12
1" (25)	31	49	11	17	160	49	58	22
1¼" (32)	44	69	16	24	224	68	81	31
1½" (40)	94	147	33	52	479	146	173	66
2" (50)	126	197	45	70	643	196	232	89
2½" (65)	206	323	73	115	1054	321	380	146
3" (80)	279	437	99	155	1424	434	513	197

Hot gas bypass capacities are based on above given temperatures. Liquid temperature is the same as condensing temperature. Evaporator temperature +40°F (+4.4°C) or less for +86°F (+30°C) condensing; -22°F (-30°C) evaporator for +15°F (-9.4°C) condensing.

† Bypass from intermediate pressure at saturation temperature to booster suction.

\*These capacities are not for hot gas defrost relief. See the chart in the middle of this page.

\*\*Optional 25% and 50% reduced capacity ¾" (20mm) plugs are available.

Discharge gas capacities are based on +15°F (+10°C) evaporator temperature.

**Liquid Line Solenoid Valve Capacities (Tons) (40F Condensing)**

Pressure Drop Across Valve (PSI)	Port Size											
	HS6		HS8		HS4A						HS4W	
	5/32"	1/2"	3/4"	1"	1 1/4"	1 1/2"	2"	2 1/2"	3"	4"	5"	6"
<b>CV</b>	<b>0.41</b>	<b>2.9</b>	<b>6.4</b>	<b>11.7</b>	<b>16.4</b>	<b>35</b>	<b>47</b>	<b>77</b>	<b>104</b>	<b>166</b>	<b>242</b>	<b>413</b>
2	2.2	16	34	63	88	188	253	414	560	893	1,302	2,222
3	2.7	19	42	77	108	231	310	507	685	1,094	1,595	2,721
4	3.1	22	49	89	125	266	358	586	791	1,263	1,841	3,142
5	3.5	25	54	100	140	298	400	655	885	1,412	2,059	3,513
7	4.1	29	64	118	165	352	473	775	1,047	1,671	2,436	4,157

CO2 Capacities are based on 40°F liquid temperature and -20°F evaporator temperature.

**CONTROL MODULES (PILOTS) FOR ANY REGULATOR**

When installed, these control modules (pilots) enable the main regulator to perform different control functions (see page 3, Regulator Variations). With the CARW product line, Pilots must be ordered separately and field installed. The nonrising stem can be adjusted by using a 1/4" wrench. Catalog numbers are for the screw-on pilot module. Do not use control modules from the standard Hansen product line on the CARW valves as these are not rated to the same duty cycle.

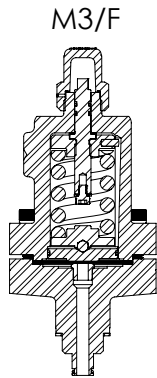

module options: MS and MSHP. MS: this is the standard module with an MOPD of 300 psid and a higher Cv through the pilot line, allowing for a 2-3 psid pressure drop across the main valve before fully opening.

MSHP: This module has an MOPD of 580 psid but a lower Cv through the pilot line, requiring approximately 5-7 psid across the valve to fully open the main valve.

Both models opens wide when energized and require a separate solenoid coil kit to operate.

**INLET PRESSURE**

Opens as inlet pressure rises. Range: F: 363-754 psig (25 to 52 bar): Catalog M3/F

**SOLENOID**

The normally closed solenoid module has been redesigned to feature a higher pressure rating and an optional higher MOPD, suitable for CO2 and other approved refrigerants. It now has a rugged one-piece stainless steel housing that screws into the module base and is sealed with a reliable aluminum gasket. There are two solenoid

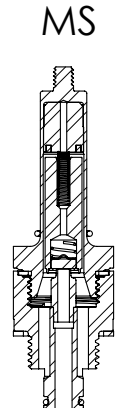

**BLANKING PLUGS**

To be used in a control module port when the port is not utilized. Stopping plugs have square head and are marked with "0" (75-1063). Straight through flow plugs have a hex head and are marked with "1" (75-1064). Catalog M3S (stopping) or M3B (straight through).



**MAIN REGULATORS ONLY**

Hansen's CARW product line are not furnished with control modules (pilot). These modules and other accessories must be purchased separately and field installed. Each CARW valve kit includes the valve body, adapter cover, gasket, bolts, NPT gauge plugs, and valve internals like piston and v-port assembly already assembled and pressure tested. The valve bodies are only offered in butt weld end connections.

CAR1W is the main regulator body with ONE control module (pilot) port, control module not included.

CAR3W is the main regulator body with THREE control module (pilot) ports, for a maximum of three control modules, not included

**TO ORDER:** Main Regulators only) Specify port size and catalog number (CARW1 or CARW3).

**(CAR1W, CAR3W)**

3/4" through 3"  
(20 mm through 80 mm)

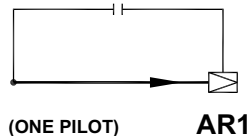

3/4" through 3"  
(20 mm through 80 mm)

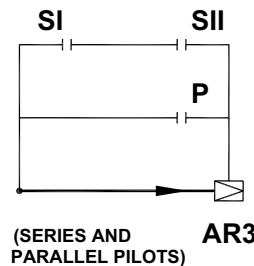

## STANDARD REGULATOR

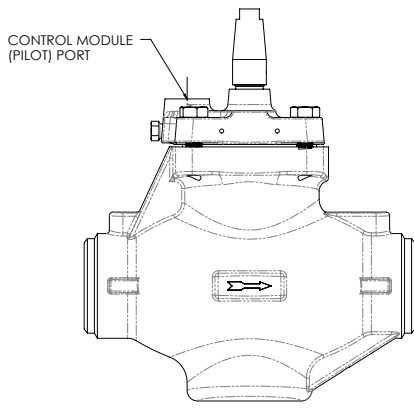

**AR1**

### EXTERNAL PILOT PIPING

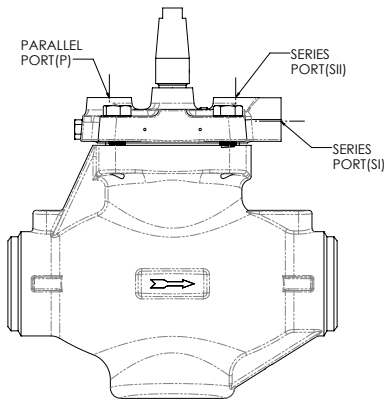
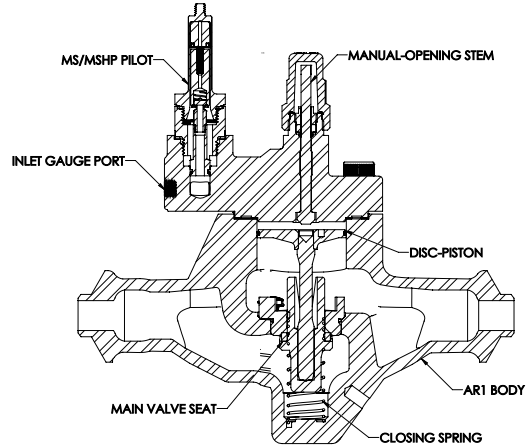

**AR3**

## OPERATION OF REGULATORS

The regulator adapter (top cover) is available with one control module port or three control module ports. One control module port is often used for a solenoid valve or a single pressure regulator. Three control module ports are often used for a dual regulator and other multiple function variations.

When the modular regulator has three control module ports, two are in series (SI and SII) and one is in parallel (P). Inlet pressure enters the internal equalization passage and goes to both the P port and the SI port. Inlet pressure enters the SII when the control module SI port is open. When the control module in the SI and SII port or the P port is open, pressure enters the space above the piston which forces the main valve seat to open and regulate flow.

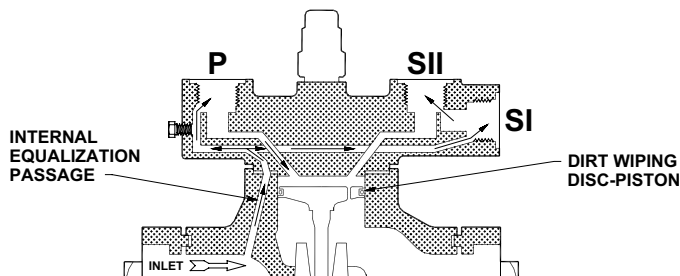

## OPERATION

Inlet pressure is channeled through the internal equalization passage to the inlet pressure control module. The valve modulates open when inlet pressure exceeds the pressure setting on the control module. The gas or liquid passes through the inlet pressure control module to enter the space on top of the piston, which forces the main valve seat to open and regulate flow. As inlet pressure increases, the main valve seat opens further to maintain the selected inlet pressure. A minimum pressure difference of 2 psi (0.14 bar g) is adequate to fully open the main valve. When inlet pressure decreases below the pressure setting on the control module, the closing spring will cause the main valve seat to throttle closed.

## ADJUSTMENT

Connect a pressure gauge via a gauge valve at the gauge port on the regulator adapter. Set the control module range spring to minimum force (control module stem turned counterclockwise). Operate the refrigeration compressor system and achieve approximate desired suction pressure. Turn the control module stem clockwise until a slight increase in inlet pressure is detected by the gauge. The inlet pressure setting can now be increased by turning the control module stem clockwise or decreased by turning it counterclockwise. The system should be allowed to operate for a period of time before the final adjustment is made. The inlet pressure control module is available in Range F, 363 to 754 psig (25 to 52 bar) only for the CARW product line.

## RESEATING RELIEF REGULATOR

### OPERATION

(Field assembly and operation are the same as a Standard Regulator) Inlet pressure is channeled through the internal equalization passage to the reseating relief control module. When inlet pressure exceeds the relief setting, the control module opens wide to allow pressure to enter the space on top of the piston. This causes the main valve seat to open and relieve the inlet pressure, provided the outlet pressure is at least 2 psi (0.14 bar g) lower.

When used for defrost relief from low side to an intermediate pressure, a check valve on the outlet is required to prevent back flow during refrigeration.

### ADJUSTMENT

Connect a pressure gauge via a gauge valve at the gauge port on the regulator adapter. Set the control module range spring at minimum force (control module stem turned counterclockwise). Operate the refrigeration compressor system and achieve approximate desired suction pressure. Turn the control module stem clockwise until a slight increase in inlet pressure is detected by the gauge. The inlet pressure setting can now be increased by turning the control module stem clockwise or decreased by turning it counterclockwise. The system should be allowed to operate for a period of time before the final adjustment is made. The inlet pressure control module is available in Range F, 363 to 754 psig (25 to 52 bar) only for the CARW product line.

## REGULATOR WITH ELECTRIC WIDE OPENING

### OPERATION

When the solenoid control module is de-energized, this control operates in the same manner as the Standard Regulator or other pilot functions. When energized, inlet pressure bypasses the constant pressure control module and enters the space on top of the piston which forces the main valve seat to open wide to permit flow in the direction of arrow.

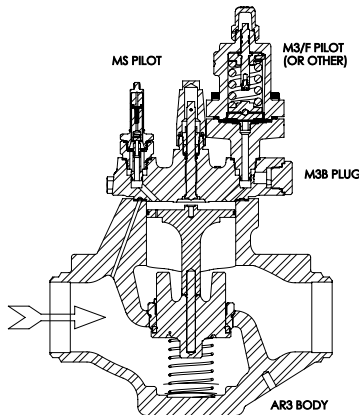

### ADJUSTMENT

With solenoid control module de-energized, follow adjustment procedures for the Standard Regulator. See page 8.

## REGULATOR WITH ELECTRIC SHUT-OFF

### OPERATION

When the solenoid control module is energized, this control operates in the same manner as the HA4A Standard Regulator or other pilot functions. When de-energized, valve closes tight to stop flow in direction of arrow regardless of pressure setting on the control module.

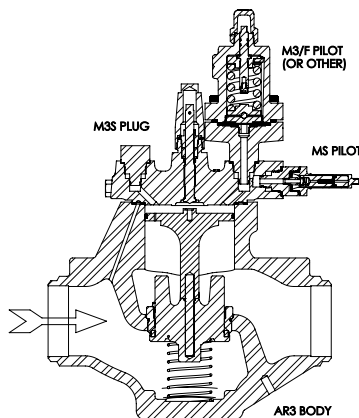

### ADJUSTMENT

Energize the solenoid control module and follow the control module adjustment procedures for the HA4A Standard Regulator. See page 10.

## DUAL PRESSURE REGULATOR

### OPERATION

When the solenoid control module is energized, this valve operates in the same manner as the HA4A Standard Regulator or other pilot functions. When the solenoid control module is de-energized, the inlet pressure is channeled to the higher-setting inlet pressure control module and operates in the same manner as the standard regulator.

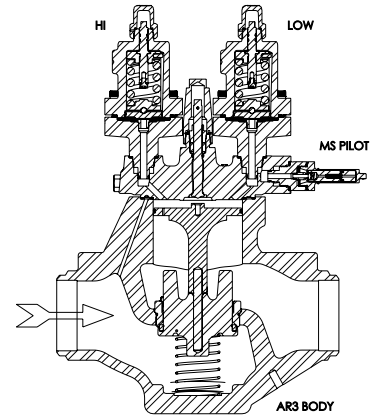

When inlet pressure rises above the higher setting, the control module opens to allow inlet pressure to enter the space on top of the piston which forces the main valve seat to open and regulate flow. Typically used as a combined evaporator pressure regulator and defrost internal relief valve.

### ADJUSTMENT

Connect a pressure gauge via a gauge valve at the gauge port on the regulator adapter. With the solenoid control module de-energized, adjust the constant pressure control module in the P port for the high-pressure setting. This may require a warm room or hot gas supply to the evaporator. Then, energize the solenoid control module located on the series SI port and adjust the constant pressure module in the series SII port for the low-pressure setting. For control module adjustment, follow the adjustment procedures for the Standard Regulator. See page 10.

## STANDARD SOLENOID

### OPERATION

When the solenoid control module is energized the valve opens wide. When deenergized, valve closes tight to stop flow in direction of arrow. MS operator (300 PSI MOPD) needs 2-3 PSI of pressure drop to fully open while MSHP (580 PSI MOPD) requires 5-7 PSI to fully open.

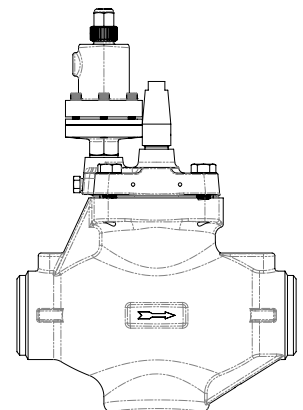

## INSTALLATION DIMENSIONS (mm)

### 3/4" THROUGH 1 1/4" REGULATORS

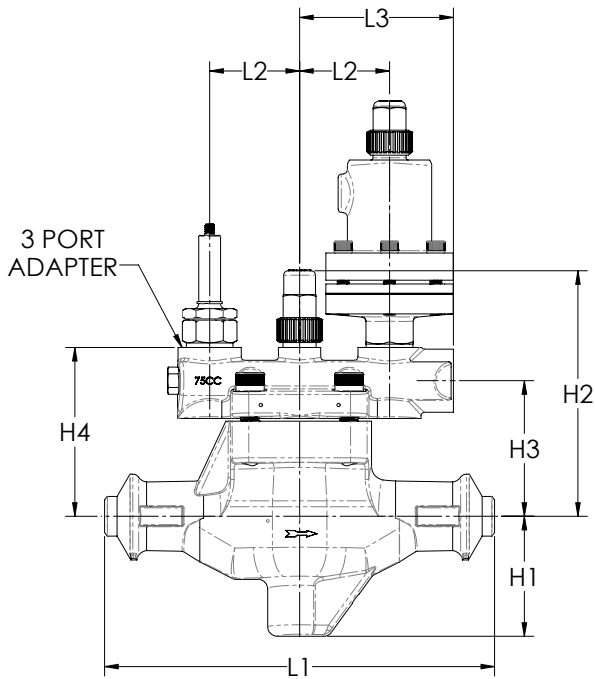

### 1 1/2" THROUGH 3" REGULATORS

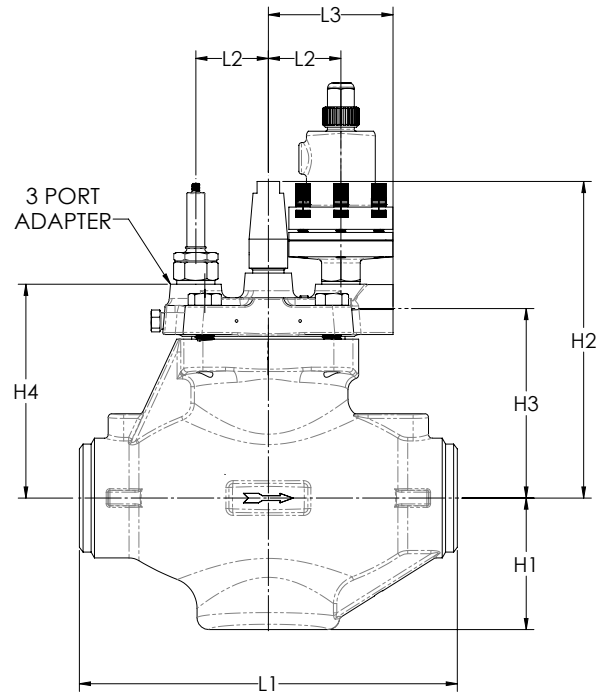

PORT SIZE (mm)	H <sub>1</sub>	H <sub>2</sub>	H <sub>3</sub>	H <sub>4</sub>	L <sub>1</sub>	L <sub>2</sub>	L <sub>3</sub>	L <sub>4</sub>	M	W*
3/4", 1", 1 1/4" (20, 25, 32)	3.09" (78)	6.77" (172)	3.75" (95)	4.63" (117)	6.19" (157)	2.38" (60)	4.07" (103)	7.20" (183)	3.70" (94)	4.50" (114)
1 1/2", 2" (40, 50)	2.87" (73)	8.84" (225)	4.90" (124)	5.72" (145)	9.88" (251)	2.35" (60)	4.04" (103)	10.89" (277)	9.83" (250)	4.50" (114)
2 1/2" (65)	3.62" (92)	9.69" (246)	5.57" (141)	6.53" (166)	9.88" (251)	2.35" (60)	4.04" (103)	11.01" (280)	9.83" (250)	5.62" (143)
3" (80)	4.06" (103)	10.00" (254)	6.03" (153)	6.88" (175)	12.25" (311)	2.35" (60)	4.04" (103)	13.38" (340)	12.20" (310)	6.50" (165)

\*Maximum width of valve.

## DIMENSION FOR CONTROL MODULES (mm)

CATALOG	M3	M3W	MS
SIZE (mm)	6.5" (165)	5.12" (130)	3.25" (83)

## PARTS LIST CONTROL MODULES

### M3F

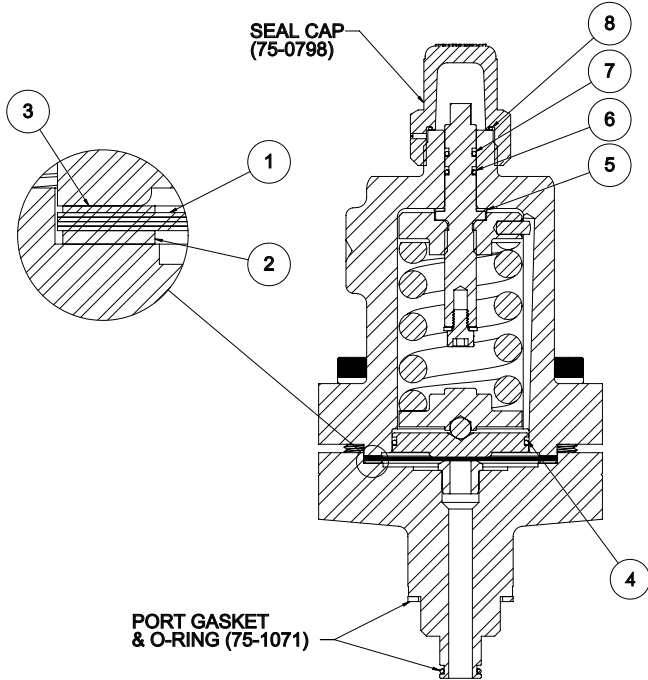

ITEM	DESCRIPTION	QTY	PART NO.
	<b>Diaphragm/Gasket Kit</b>		<b>75-1514</b>
	<b>M3/F</b>		
	<i>Above kit consists of:</i>		
1	DIAPHRAM	4	75-0371
2	LOWER GASKET (THICK)	1	75-0426
3	UPPER GASKET (THIN)	1	75-0636
4	FOLLOWER O-RING	1	75-0337
5	FIBER WASHER	1	75-0617
6	LOWER STEM O-RING (GREEN DOT)	1	75-0520
7	UPPER STEM O-RING	1	75-0521
8	SEAL CAP O-RING	1	75-0011

### MS/MSHP

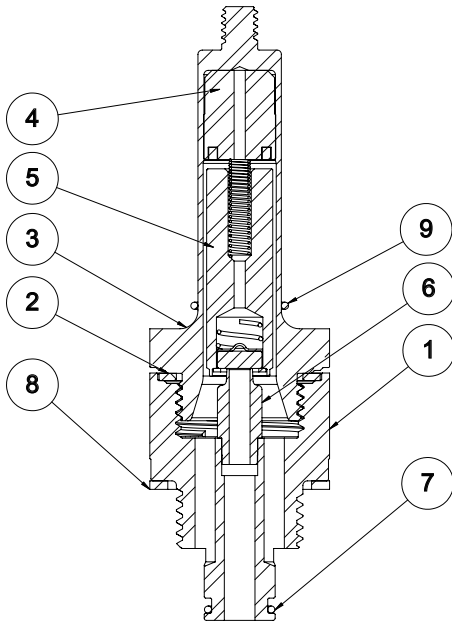

ITEM	DESCRIPTION	QTY	PART NO.
	<b>SOLENOID MODULE KIT ( MS OR MSHP )</b>		<b>MS</b>
			<b>or MSHP</b>
	<i>Above kit consists of:</i>		
1	SOLENOID MODULE BASE	1	
2	SOLENOID TUBE ALUMINIUM GASKET	1	
3	SOLENOID TUBE	1	
4	SOLENOID STOP	1	
5	PLUNGER ASSEMBLY	1	
6	STANDARD SOLENOID SEAT	1	
7	PORT O-RING	1	
8	PORT GASKET	1	
9	COIL O-RING	1	

**PARTS LIST 3/4" THROUGH 1 1/4" (20mm THROUGH 32mm)**

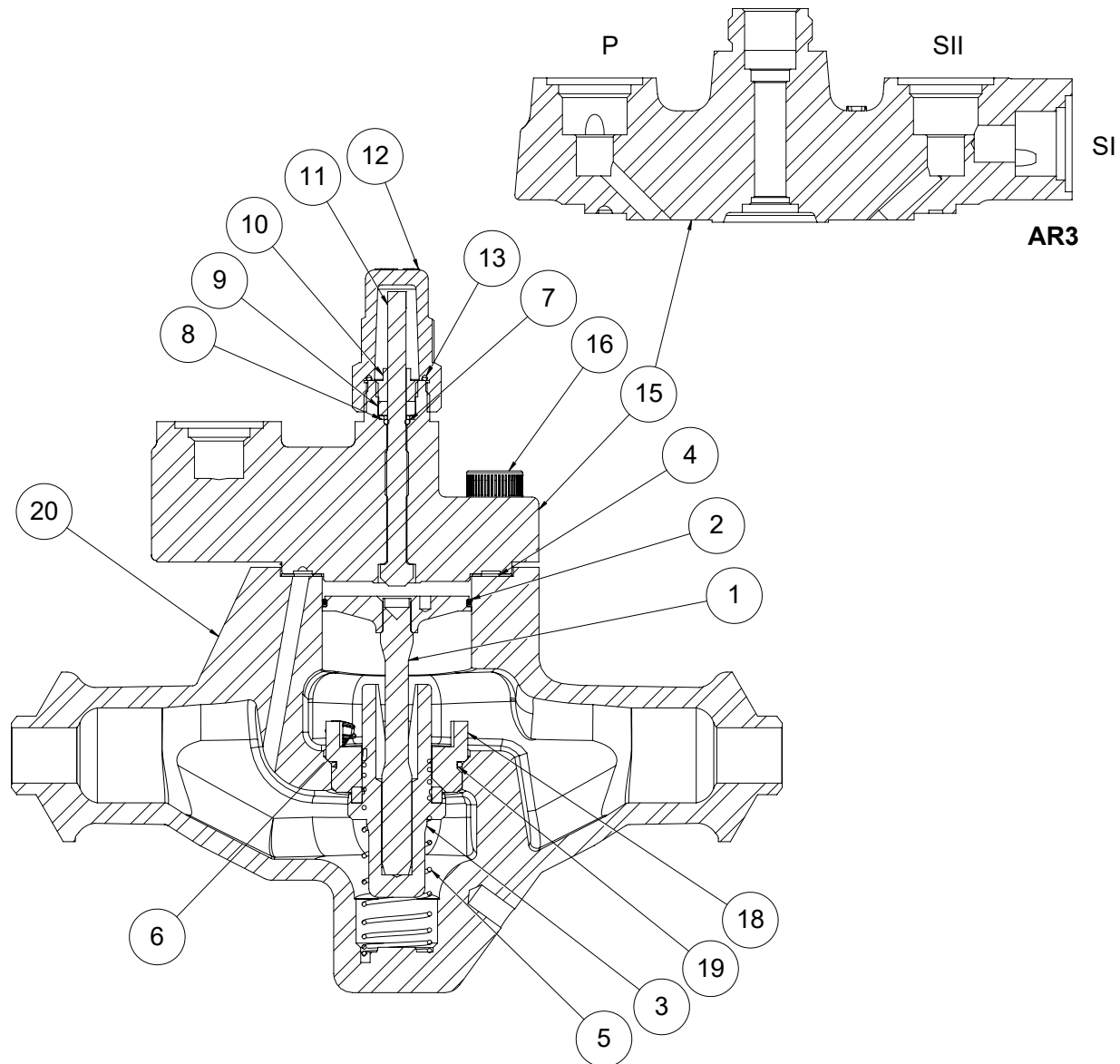

ITEM	DESCRIPTION	QTY.	KIT NO
	<b>Gasket Kit consists of:</b>		<b>75-1023</b>
4	Adapter Gasket	1	
7	Stem O-ring	1	
8	Stem Washer	1	
9	Stem Packing	1	
10	Packing Nut	1	
13	Seal Cap O-ring	1	
19	Seat Seal O-ring	1	
	<b>Piston Kit consists of:</b>		<b>75-1500</b>
1	Piston	1	
2	Piston Seal	1	
4	Adapter Gasket	1	
	<b>3/4" V-port Kit* consists of:</b>		<b>75-1501</b>
	<b>1" V-port Kit* consists of:</b>		<b>75-1502</b>
	<b>1-1/4" V-port Kit* consists of:</b>		<b>75-1503</b>
3	V-port	1	
4	Adapter Gasket	1	
5	Closing Spring	1	
6	set screw	1	
19	Seat Seal O-ring	1	

	<b>Adapter Kit, 1-port consists of:</b>		<b>75-1508</b>
	<b>Adapter Kit, 3-port consists of:</b>		<b>75-1509</b>
15	Adapter	1	
4	Adapter Gasket	1	
7	Stem O-ring	1	
8	Stem Washer	1	
9	Stem Packing	1	
10	Packing Nut	1	
11	Manual Open Stem	1	
12	Seal Cap Kit	1	
14	Gauge Port Plug (1/4" NPT)	1	
16	Adapter Hex Screws (1/2"-13 x 1-1/2")	4	
17	Plug, 1/8"-27 NPT Hex Socket	1	
	<b>Seal Cap Kit consists of:</b>		<b>50-1071</b>
12	Seal Cap	1	
13	Seal Cap O-ring	1	
18	Seat Ring	1	
20	Body	1	

**PARTS LIST 1½" THROUGH 3" (40mm THROUGH 100mm)**

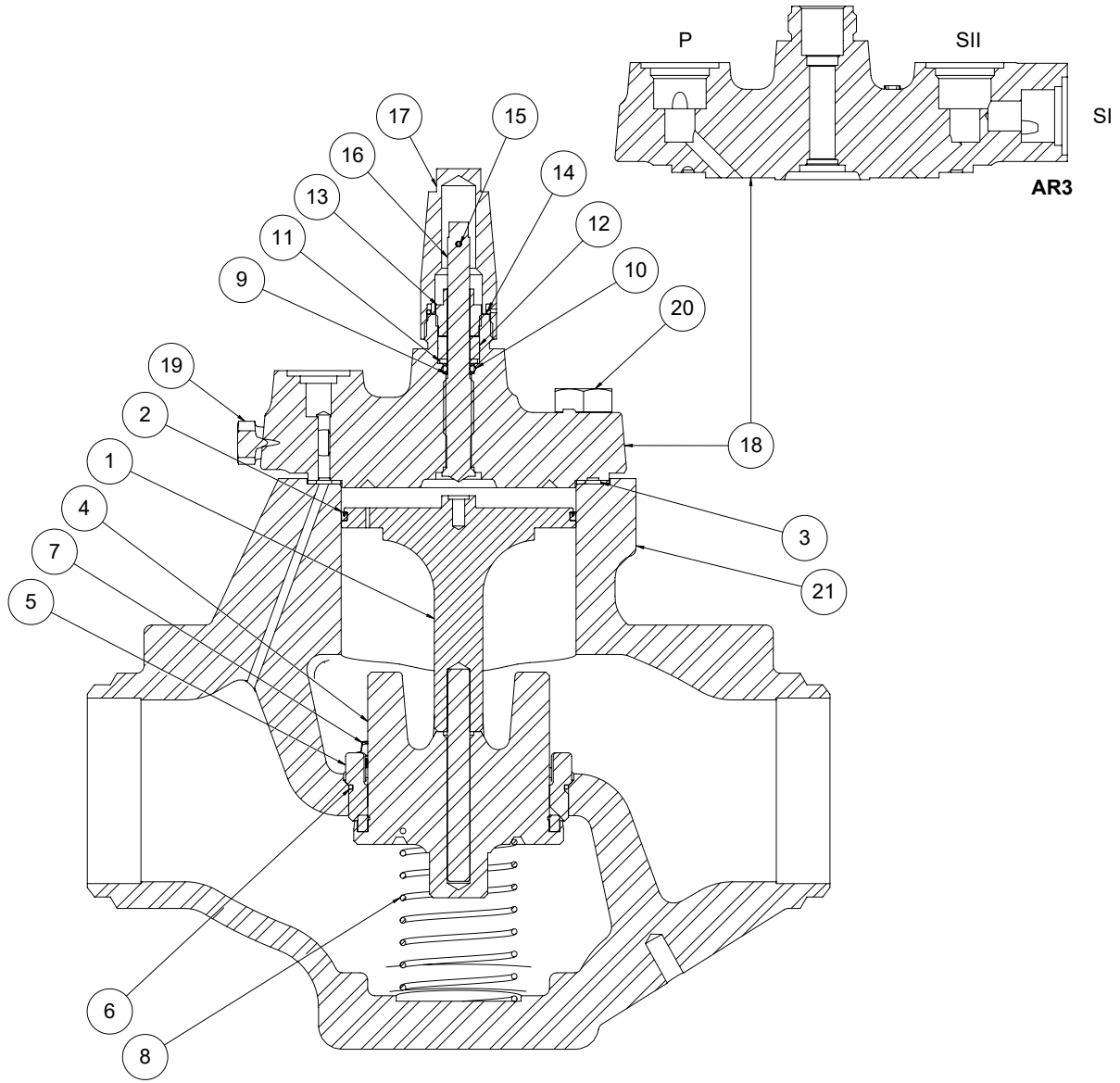

ITEM	DESCRIPTION	QTY.	KIT NO
	<b>1-1/2", 2" Gasket Kit consists of:</b>		<b>75-1039</b>
	<b>2-1/2", Gasket Kit consists of:</b>		<b>75-1040</b>
	<b>3", Gasket Kit consists of:</b>		<b>75-1041</b>
3	Adapter Gasket	1	
6	Seat Seal O-ring	1	
9	Back-up Washer	1	
10	Stem O-ring	1	
11	Stem Washer	1	
12	Stem Packing	1	
13	Packing Nut	1	
14	Seal Cap O-ring	1	
15	Stem Pin	1	
	<b>1-1/2", 2" Piston Kit consists of:</b>		<b>75-1025</b>
	<b>2-1/2" Piston Kit consists of:</b>		<b>75-1026</b>
	<b>3" Piston Kit consists of:</b>		<b>75-1027</b>
1	Piston	1	
2	Piston Seal	1	
3	Adapter Gasket	1	
	<b>1-1/2" V-port Kit consists of:</b>		<b>75-1504</b>
	<b>2" V-port Kit consists of:</b>		<b>75-1505</b>
	<b>2-1/2" V-port Kit consists of:</b>		<b>75-1506</b>
	<b>3" V-port Kit consists of:</b>		<b>75-1507</b>
4	V-port	1	
3	Adapter Gasket	1	

6	Seat Seal O-ring	1	
7	set screw	1	
8	Closing Spring	1	
	<b>1-1/2", 2" Adapter Kit, 1-port consists of:</b>		<b>75-1510</b>
	<b>1-1/2", 2" Adapter Kit, 3-port consists of:</b>		<b>75-1511</b>
	<b>3" Adapter Kit, 1-port consists of:</b>		<b>75-1512</b>
	<b>3" Adapter Kit, 3-port consists of:</b>		<b>75-1513</b>
18	Adapter	1	
3	Adapter Gasket	1	
9	Back-up Washer	1	
10	Stem O-ring	1	
11	Stem Washer	1	
12	Stem Packing	1	
13	Packing Nut	1	
14	Seal Cap O-ring	1	
15	Stem Pin	1	
16	Manual Open Stem	1	
17	Seal Cap Kit	1	
19	Gauge Port Plug (1/4" NPT)	1	
20	Adapter Hex Screws (1/2"-13 x 1-1/2")	4	
	<b>1-1/2" thru 3" Seal Cap Kit consists of:</b>		<b>75-1014</b>
17	Seal Cap	1	
14	Seal Cap O-ring	1	
5	Seat Ring	1	
21	Body	1	

## SERVICE AND MAINTENANCE

**Failure to open:** Wrong coil or control module pilot; low line voltage; controlling switch or thermostat not contacting; coil is burned-out; adjacent shut-off valve closed; adapter gasket hole not aligned with hole in body and adapter; dirt packed under Teflon seal ring enabling excessive blow by; large quantity of dirt particles in solenoid module passages; dirt blocking internal pilot passages; main valve seat is dirt jammed. Exceeding rated MOPD for chosen solenoid module. Check to make sure that the pressure differential across the valve is below rated.

**Failure to close:** Controlling switch or thermostat not opening contacts; manual-opening stem is turned in; valve installed in wrong direction; damage or dirt at main valve seat or pilot seat; piston bleed hole plugged. Under extreme conditions of liquid or oil “slugging” or pressure drops exceeding 45 psi (3.1 bar g), special construction may be required. Contact the factory.

Before opening the regulator or disassembling the pilot for service, be sure it is isolated from the system and all refrigerant is removed (pumped out to zero pressure). Follow usual refrigeration system safe servicing procedures. Read the CAUTION section of this bulletin on page 20.

To check solenoid pilot section of valve, disconnect the electrical coil. Unscrew the coil nut. Lift coil housing away from valve. Remove entire solenoid module from valve by unscrewing from cover adapter. Do not remove the top tube housing from the base of the solenoid module. Inspect for signs of dirt and damage to pilot orifices. Clean, or replace parts as necessary, then reassemble. Plunger or aluminum gasket kits will not be offered and it is recommended to replace the entire module if there is damage to one of the parts. For 3/4" to 1-1/4" (20mm to 32mm) male hexagon wrench to loosen the four adapter bolts, proceeding slowly to avoid refrigerant which may still remain in the valve. If piston parts are stuck, use a pair of needle nose pliers to grab onto metal between the blind drill hole and larger central hole to remove. For 1-1/2" to 3" (40mm to 80mm), Loosen adapter bolts using a 12" adjustable wrench being careful to avoid any refrigerant which may still remain in the valve. If disc piston is difficult to remove, insert a 1/4"-20 threaded screw into center of piston and lift straight-up. Inspect disc and piston bore for burrs, nicks, and other damage. Remove burrs and nicks, clean or replace disc piston and Teflon seal ring as necessary. Long-life seal on disc piston need only be replaced when damaged or severely worn. If replacing the disc piston seal, make sure the seal is properly installed, with the edge up, and does not “twist” during installation. Inspect V-port/seat and main valve seat for nicks, marks, etc. The main valve seat may be lapped by hand or may be removed and replaced. Clean, polish or replace parts as necessary. Lightly lubricate all parts and gaskets with soft rag containing refrigerant oil. Align hole in valve body, adapter gasket, and adapter to assure proper operation.

## MANUAL OPENING

The manual-opening stem is designed to open the valve, allowing upstream and downstream pressures to equalize when needed for servicing, but not necessarily to create a full-flow condition. The stem is located on the top of the adapter cover. Slowly remove the seal cap from the manual-opening stem, being cautious to avoid any refrigerant which may have collected under the cap. Using an appropriate wrench, turn the stem in (clockwise) to open the valve manually; counterclockwise to return the valve to automatic operation. Do not leave the stem partially open because it may be dynamically damaged. Reassemble valve. Carefully check valve for leaks before returning it to service.

## ORDERING INFORMATION, MODULAR PRESSURE REGULATORS

PORT SIZE (mm)	CONNECTION STYLES & SIZES		
	End Connection	Adapter Cover	
	BW STD	1 PORT	3 Port
3/4" (20)	3/4"	CAR1W/20	CAR3W/20
1" (25)	1"	CAR1W/25	CAR3W/25
1-1/4" (32)	1-1/4"	CAR1W/32	CAR3W/32
1-1/2" (40)	1-1/2"	CAR1W/40	CAR3W/40
2" (50)	2"	CAR1W/50	CAR3W/50
2-1/2" (65)	2-1/2"	CAR1W/65	CAR3W/65
3" (80)	3"	CAR1W/80	CAR3W/80

## TYPICAL SPECIFICATIONS

“Refrigerant pressure regulators shall be pilot-operated, with disc-type pistons having Teflon seals, manual-opening stems, available to be equipped with removable pilot modules, as manufactured by Hansen Technologies Corporation or approved equal.”

## OTHER PRODUCTS

Small Pressure Regulators and Reliefs  
Gauge, Purge, and Needle Valves  
Shut-Off Valves  
Hand Expansion Valves (Regulators)  
Refrigerant Solenoid Valves  
Refrigerant Check Valves  
Gas-Powered Valves  
Refrigerant Float Switches  
Float Drain Regulators  
AUTO-PURGER®s  
Vari-Level® Adjustable Level Controls  
Frost Master® Defrost Controllers  
Pressure-Relief Valves

## **CAUTION**

Hansen valves are for refrigeration systems only. These instructions must be completely read and understood before selecting, using or servicing Hansen valves and electronics. Only knowledgeable, trained refrigeration mechanics should install, operate, or service. Stated temperature and pressure limits should not be exceeded. Bonnets, solenoid tubes, etc. should not be removed from valves unless system has been evacuated to zero pressure. See also Safety Precautions in the current List Price Schedule and the Safety Precautions Sheet supplied with the product.

## **WARRANTY**

All Hansen products, except electronics, are guaranteed against defective materials or workmanship for one year F.O.B. factory. Electronics are guaranteed against defective materials or workmanship for 90 days F.O.B. factory. No consequential damages or field labor is included.

# **H HANSEN**

Hansen Technologies Corporation

3475 Old Maysville Rd

Commerce, Georgia 30529 USA

Tel: 630.325.1565 Fax: 630.325.1572 Toll: 800.426.7368

Email: [sales@hantech.com](mailto:sales@hantech.com) Web: [www.hantech.com](http://www.hantech.com)

**USA · Asia · Europe · India · Latin America · Middle East**

© 2015 Hansen Technologies Corporation